



# BMW Wallbox Plus

**INSTRUCTIONS FOR USE.  
ORIGINAL BMW ACCESSORIES.**





# BMW Wallbox Plus

## Instructions for use

### Contents

2 Overview	13
3 Requirements	15
4 Installation	17
5 Connect terminal	22
6 Configuration via Wallbox Installation App	24
7 Commissioning	25
8 Operation	27
9 Status LED information	34
10 Maintenance	35
11 Moving and storage	37
12 Technical data	38
13 Disposal	41

# 1 Information

## 1.1 Symbols used



Denotes instructions or warnings that you must observe. ◀



Denotes instructions that draw your attention to special features. ◀



Denotes the end of the instruction.

## 1.2 Safety information

Read the safety information carefully and familiarise yourself with the device before you attempt to install, operate or service it.



- Electrical danger! The BMW Wallbox Plus must be installed, commissioned and serviced by appropriately trained, qualified and authorised electricians (1) who bear full responsibility for compliance with current standards and installation regulations.
- Please note that an additional overvoltage protector may be required by vehicle or national regulations. Please refer to your national connection and installation standards.
- Before commissioning the device, check that all screw and terminal connections are tight. The terminal panel must never be left open without supervision. Fit the terminal panel cover when you leave the BMW Wallbox Plus.
- Do not make any unauthorised changes or modifications to the BMW Wallbox Plus.
- Repair work to the BMW Wallbox Plus is not permitted and may only be completed by the manufacturer or a trained expert (BMW Wallbox Plus replacement).
- Do not remove any identifiers such as safety symbols, warning instructions, rating plates, labels or cable markings.
- The BMW Wallbox Plus does not have its own mains switch. The residual current operated circuit breaker and circuit breaker on the building installation is used as a mains isolation device.
- Pull out the connector by the plug, not the cable.
- Ensure that the vehicle connector is not mechanically damaged (kinked, jammed or run over) and that the contact area does not come into contact with heat sources, dirt or water.
- Do not touch the contacts of the connector. ◀

(1) People who, as a result of training, skills, experience and the knowledge of the relevant standards, can assess the work and identify possible dangers.



- Always conduct a visual inspection for signs of damage before charging. Pay particular attention to dirt and moisture on the plug, cuts on the vehicle connector cable or chafing on the insulation, and also ensure that the cable output from the BMW Wallbox Plus is securely fastened.
- Never clean the BMW Wallbox Plus using a jet of water (hosepipe, pressure washer, etc.)
- Ensure that the BMW Wallbox Plus is not damaged by incorrect handling (housing cover, internal parts, etc.).
- If it is raining or snowing and the BMW Wallbox Plus is installed outdoors, do not open the terminal panel cover.
- Do not break the plastic housing by use of excessive force.
- Do not use countersunk screws to secure the device.
- Do not tighten the securing screws with excessive torque, follow the instruction on the torque mentioned in the manual.
- The installation area must be completely flat (max. 1 mm difference between the support and securing points). Do not bend the housing.
- If any sealing is broken, the security and safety can no longer be ensured and BMW and its affiliates are not liable for damages and/or losses related to such disturbances, security breaches, unauthorised access, interfaces, intrusion, leakage and/or theft of data or information. ◀

Information for trained personnel who may open the device: Danger of damage. Electronic components may be destroyed if touched. Before handling modules, perform an electrical discharge process by touching a metallic grounded object. Failure to follow the safety information may result in danger of death, injury and damage to the device. The device manufacturer cannot accept any liability for claims resulting from this.

### **1.3 Intended use / compatibility**

The BMW Wallbox Plus has been developed for use with all BMW Group fully electric and hybrid vehicles and all vehicles which comply with national regulations (with the exception of vehicles with a simplified pilot circuit).

The BMW Wallbox Plus is a charging station for indoor and outdoor use for charging electric or plug-in hybrid vehicles. Do not connect any other devices to it, e.g. electric tools. The BMW Wallbox Plus is designed for installation on a wall or column. You must comply with the relevant national regulations for installing and connecting the BMW Wallbox Plus.

The intended use of the device in every case includes compliance with the ambient conditions for which this device was developed.

The BMW Wallbox Plus was developed, manufactured, tested and documented on the basis of the relevant safety standards. If you comply with the instructions and safety information described for its intended use, the product normally will not pose any danger in terms of property damage or to the health of people.

This device must be grounded. In the event of an error, the ground connection will reduce the danger of an electric shock. The use of adapters and cord extension sets is not permitted.

The instructions contained in this manual must be followed to the letter. Otherwise, sources of danger may be created or safety equipment may be rendered inoperable. In addition to the safety information provided in this manual, the safety and accident prevention regulations relating to the specific device must be followed.



Designed for NACS charging sockets.

For J1772 (Type 1) charging sockets simply connect the BMW NACS Adapter to enjoy charging.

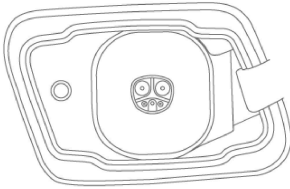

NACS

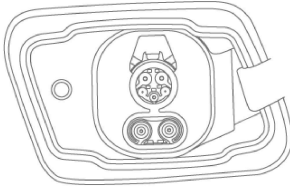

J1772 (Type 1)

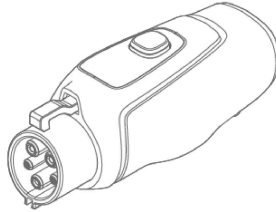

NACS (AC) Adapter



See also BMW NACS Adapter manual.

## 1.4 About this manual

This manual and the functions described in it are valid for devices of the following type:

**61 90 5 A7A 8A3**

This manual is designed exclusively for trained personnel. These are people who, as a result of their training, skills and experience as well as their knowledge of the relevant standards, can assess the work assigned to them and identify possible dangers.

The illustrations and explanations contained in this manual refer to a typical version of the device. Your device version may differ from this.

Please refer to the operating manual for information and instructions for operating the device.

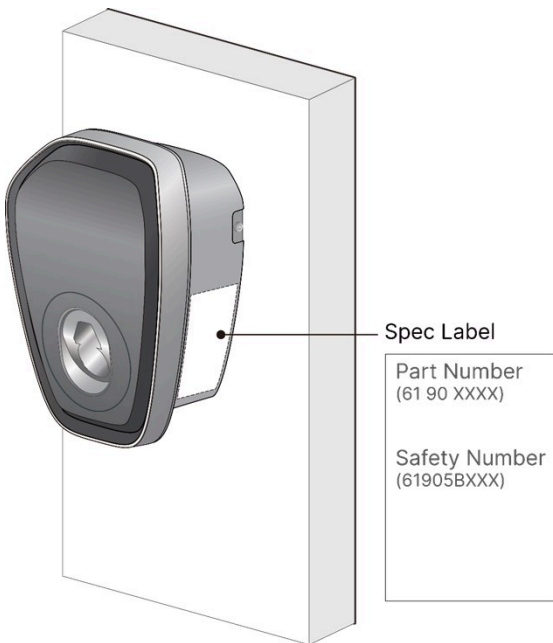
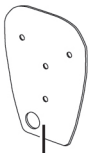
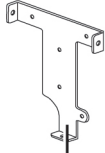

Illustration: Location of specifications label/type plate.

## 1.5 Package



A



B



C



D



E



F

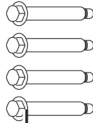

G



H



I

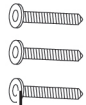

J

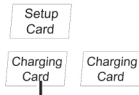

K



L



M

A Mounting template

B Mounting bracket

C Cable holder

D Design cover

E No.8 wood screws (4x)

F Torx T30 mounting bolts (3x)

G 1/4" expansion bolts (4x)

H Torx T20 anti-theft screw

I Middle cover screw (4x)

J M6 hex socket cable holder screw (3x)

K Setup card, charging card (2x)

L Safety Guide (contains important information and passwords and must be kept safe)

M NPT-1 cable gland

## 1.6 Warranty

BMW Service and Sales personnel can provide more information on the terms of the warranty. However, the following cases are not covered by the warranty.



- Defects or damage caused by installation work which was not carried out as specified in the BMW Wallbox Plus installation instructions.
- Defects or damage caused by the product not being used as specified in the BMW Wallbox Plus operating manual.
- Costs and damage caused by repair work not carried out by a specialist electrician authorised by a BMW sales outlet or authorised service workshop. ◀

## 1.7 Federal Communications Commission Interference Statement

This equipment has been tested and found to comply with the limits for a Class B digital device, pursuant to part 15 of the FCC Rules. These limits are designed to provide reasonable protection against harmful interference in a residential installation. This equipment generates, uses and can radiate radio frequency energy and, if not installed and used in accordance with the instructions, may cause harmful interference to radio communications. However, there is no guarantee that interference will not occur in a particular installation. If this equipment does cause harmful interference to radio or television reception, which can be determined by turning the equipment off and on, the user is encouraged to try to correct the interference by one or more of the following measures:

- Reorient or relocate the receiving antenna.
- Increase the separation distance between the equipment and receiver.
- Connect the equipment into an outlet on a circuit different from that to which the receiver is connected.
- Consult the dealer or an experienced radio/ TV technician for help.



Any changes or modifications not expressly approved by the grantee of this device could void the user's authority to operate the equipment.

This device complies with Part 15 of the FCC Rules. Operation is subject to the following two conditions: (1) this device may not cause harmful interference, and (2) this device must accept any interference received, including interference that may cause undesired operation. ◀

The device shall automatically discontinue transmission in case of either absence of information to transmit or operational failure.

These provisions are not intended to preclude the transmission of control or signalling information or the use of repetitive codes used by certain digital technologies to complete frame or burst intervals.

This device is slave equipment. The device is not intended for radar detection or ad-hoc operation in the DFS band.

The equipment complies with FCC RF exposure limits set forth for an uncontrolled environment. The equipment must not be co-located or operating in conjunction with any other antenna or transmitter. This equipment must be installed and operated in accordance with the provided instructions and the antenna(s) used for this transmitter must be installed to provide a separation distance of at least 25 cm from all persons and must not be co-located or operating in conjunction with any other antenna or transmitter. End-users and installers must be provided with antenna installation instructions and transmitter operating conditions for satisfying RF exposure compliance.

## 1.8 Industry Canada Statement

### Canada, Industry Canada (IC) Notices

This device contains licence-exempt transmitter(s)/receiver(s) that comply with Innovation, Science and Economic Development Canada's licence-exempt RSS(s). Operation is subject to the following two conditions:

1. This device may not cause interference.
2. This device must accept any interference, including interference that may cause undesired operation of the device.

CAN ICES (B) / NMB (B)



User should also be advised that:

- (i) the device for operation in the band 5150-5250 MHz is only for indoor use to reduce the potential for harmful interference to co-channel mobile satellite systems;
- (ii) the maximum antenna gain permitted for devices in the bands 5250-5350 MHz and 5470-5725 MHz shall comply with the EIRP limit; and
- (iii) the maximum antenna gain permitted for devices in the band 5725-5825 MHz shall comply with the EIRP limits specified for point-to-point and non point-to-point operation as appropriate. High-power radars are allocated as primary users (i.e. priority users) of the bands 5250-5350 MHz and 5650-5850 MHz and that these radars could cause interference and/or damage to LE-LAN devices. ◀

## Radio Frequency (RF) Exposure Information

The radiated output power of the Wireless Device is below the Innovation, Science and Economic Development Canada (ISED) radio frequency exposure limits. The Wireless Device should be used in such a manner that the potential for human contact during normal operation is minimised.

This device has also been evaluated and shown compliant with the IC RF exposure limits under portable exposure conditions. Antennas must be positioned at least 25 cm away from a person's body.

## 1.9 Device in Costa Rica

The mobile telecommunications network modules (2G/3G/LTE/WWAN) have been permanently disabled in Costa Rica.

## 1.10 Important Safety Instructions



When using electric products, basic precautions should always be followed, including the following. This manual contains important instructions for Model 61905B30091 that shall be followed during installation, operation and maintenance of the unit. ◀

1. Read all the instructions before using this product.
2. This device should be supervised when used around children.
3. Do not put fingers into the electric vehicle connector.
4. Do not use this product if the flexible power cord or EV cable are frayed, have broken insulation or any other signs of damage.
5. Do not use this product if the enclosure or the EV connector is broken, cracked, open or shows any other indication of damage.

### SAVE THESE INSTRUCTIONS

A device employing pressure terminal connectors for field wiring connections shall be provided with instructions specifying a range of values or a nominal value of tightening torque to be applied to the clamping screws of the terminal connectors.

### GROUNDING INSTRUCTIONS AND INSTALLATION INSTRUCTIONS

This product must be connected to a grounded, metal, permanent wiring system, or an equipment grounding conductor must be run with the circuit conductors and connected to the equipment grounding terminal or lead on the product.

The device must be mounted at a sufficient height such that the storage means for the coupling device is positioned between 600 mm (24 inches) and 1.2 m (4 feet) above ground level.

## 2 Overview

### 2.1 Display and controls

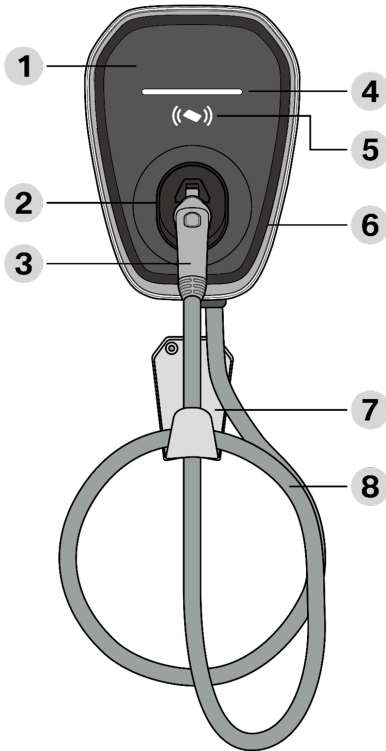

1. Design cover
2. Vehicle connector inlet
3. Vehicle connector (NACS)
4. LED indicator
5. RFID reader
6. Middle cover
7. Cable holder
8. Charging cable

## 2.2 Quick Start Guide for commissioning the BMW Wallbox Plus

1. Downloading and installing the Wallbox Installation App.
2. Scan the following QR code; it can also be found on the 'Installation: first steps' of the Safety Guide and in Section 6 of these operating instructions.



Wallbox Installation App for **iOS**



Wallbox Installation App for **Android**

3. Mounting and installing the BMW Wallbox Plus. See Sections 3 to 7 in these operating instructions or the installation instructions in the Wallbox Installation App.
4. Setting up and configuring the BMW Wallbox Plus via the Wallbox Installation App.
  - a) Establishing a Bluetooth connection with the Wallbox. Please scan the multifunctional QR code with individual access information on the **password sticker** in 'Installation: first steps' of the Safety Guide (see Figure 1 below for an example of the QR code).
  - b) Setup and configuration using the Installation Wizard of the Wallbox Installation App.
5. Optional: Activating access control via RFID card (Section 8).
6. Configuration validation and configuration test via the Installation Wizard of the Wallbox Installation App.

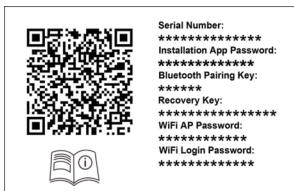

Figure 1: Example of the password sticker in the Safety Guide.

## 3 Requirements

### 3.1 General criteria for selecting an installation site

The BMW Wallbox Plus has been designed for indoor and outdoor use. It is therefore necessary to ensure the correct installation conditions and protection for the device at the installation site.

- Take into account the local electrical installation regulations, fire prevention regulations and accident prevention regulations as well as the rescue routes at the site.
- Do not install the BMW Wallbox Plus at locations:
  - Which are used as escape and rescue routes.
  - Which are inside potentially explosive zones.
  - At which the BMW Wallbox Plus is exposed to ammonia or ammonia gases.
  - At which the BMW Wallbox Plus may be damaged by falling objects.
  - At which the BMW Wallbox Plus is on a direct personnel route and people could stumble over the connected vehicle connector.
  - At which the BMW Wallbox Plus may be struck by jets of water.
  - At which the installation surface does not have sufficient strength to withstand the mechanical stresses.
- If possible, install the BMW Wallbox Plus so that it is protected from direct rainfall so as to avoid the effects of weather, icing, damage by hailstones or similar.
- If possible, install the BMW Wallbox Plus so that it is protected from direct sunlight to prevent the charging current being reduced or the charging process being interrupted as a result of excessive temperatures on components of the BMW Wallbox Plus.
- Comply with the permitted ambient conditions, see Technical data section.
- Ensure compliance with national and international installation standards and regulations.

## 3.2 Specifications for the electrical connection

Using the Installation Wizard in the Wallbox Installation App, ensure that the maximum current is set in line with the installed circuit breaker.

### Selecting the circuit breaker

When selecting the circuit breaker, the standard value of the rated conditional residual short-circuit current is 1500 A for the BMW Wallbox Plus. Also take into consideration the increased ambient temperatures in the control cabinet. Under certain circumstances, this may require a reduction in the charging current settings to increase the system availability.

Set the rated current to suit the model plate details in conjunction with the required charging power and the supply cable.



To reduce the risk of fire, connect only to a circuit provided with 80 amperes maximum branch circuit overcurrent protection in accordance with the National Electrical Code, ANSI/NFPA 70 and the Canadian Electrical Code, Part I, C22.1.

A circuit breaker with 80 A min., 250 V min. must be used.

### Selecting the supply cable

When selecting the supply cable, take into account the possible reduction factors and the increased ambient temperatures in the internal connection area of the BMW Wallbox Plus, see the temperature rating of the supply terminals. Under certain circumstances, this may require an increase in the cable cross-section and an adjustment in the temperature resistance of the supply cable.

### Mains isolation device

The BMW Wallbox Plus does not have its own mains switch. The residual-current-operated circuit breaker and/or the circuit breaker in the supply cable are used as a mains isolation device.

### Grounding

If the PE resistance does not meet local regulatory requirements, additional ground rods are recommended.

## 4 Installation

### 4.1 Installation requirements

- Follow the local installation regulations.
- Acclimatisation: If there is a temperature difference of more than 15°C between transport and the installation site, the BMW Wallbox Plus must be acclimatised unopened for at least two hours. Opening the BMW Wallbox Plus immediately may result in condensation formation in the interior and cause damage when the device is switched on. Under certain circumstances, damage caused by condensation formation may also not appear until a later date after the installation. Ideally, the BMW Wallbox Plus should be stored for a few hours in advance at the installation site. If this is not possible, the BMW Wallbox Plus should not be stored in low temperatures (< 5°C) overnight outdoors or in a vehicle.

### Tool list

- Electric drill (only for masonry walls)
- Torx T30 screw driver
- Torx T20 screw driver
- Phillips #2 screw driver
- Terminal crimpers
- Cable of appropriate trade size for signal lines, RS-485 (0.75 mm<sup>2</sup>) M25. The RS-485 cable must meet the UL2919 requirement.

### 4.2 Recommended installation positions

When selecting the installation position, take note of the position of the charge connector on your vehicle and the direction in which you normally park it.

The unit must be mounted on one of the following types of (solid) walls only:

- Non-cracked concrete or solid brick: Use the three 1/4" concrete anchor screws provided to secure the charger unit onto the wall.
- Solid wood or drywall and solid wood (wall stud): Use the three No. 8 wood screws provided to secure the charger unit onto the wall.

### 4.3 Required distance

Follow applicable accessibility requirements for the mounting position. The unit must be mounted at a sufficient height from ground such that the storage height is located between 1,000 mm (39 inches) and 1,200 mm (47 inches).

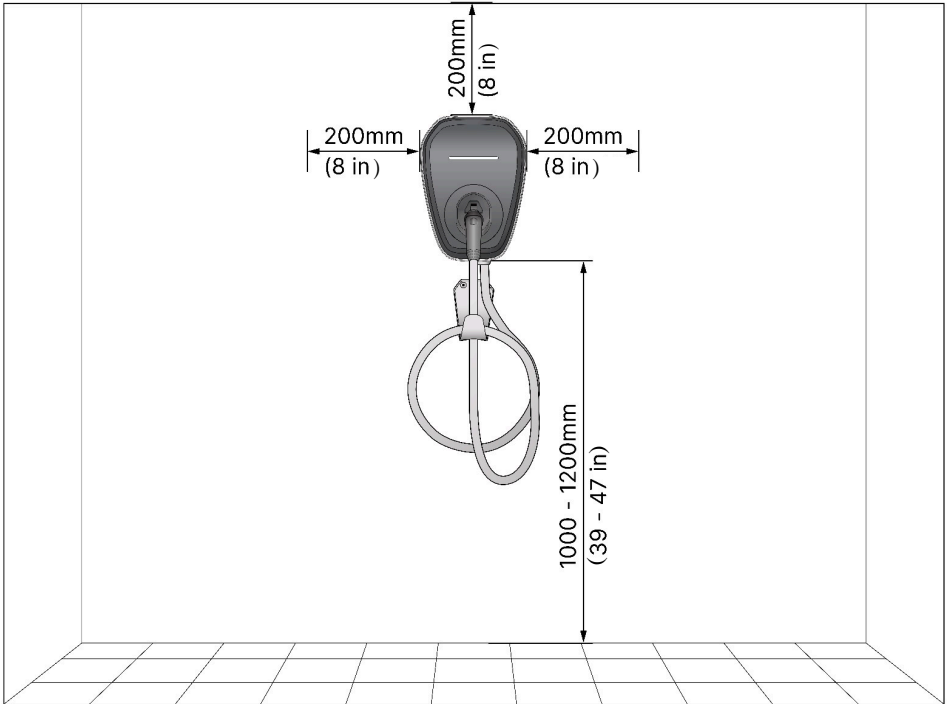

## 4.4 Mounting the BMW Wallbox Plus

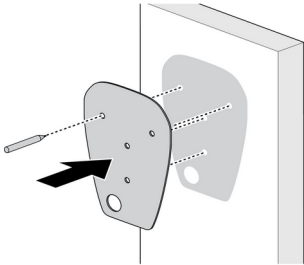
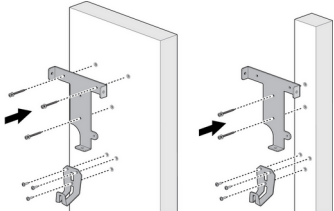
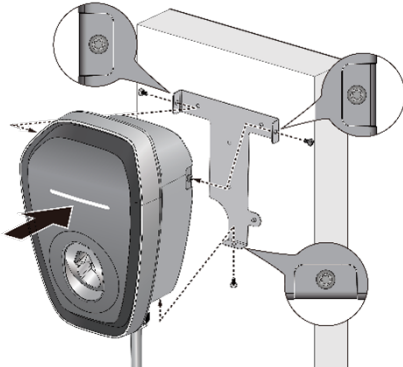
	<p>1. The product is a stationary, wall-mounted device. It includes mounting template [Section 1.4, Figure <b>A</b>] to mark the bolt/screw positions for the mounting bracket and the cable holder (optional).</p>
	<p>2. Fasten mounting bracket [Section 1.4, Figure <b>B</b>] to the wall. The cable holder is optional and depicted in the figure for demonstration purposes.</p> <p>The following bolt/screw types are recommended:</p> <ul style="list-style-type: none"><li>- Masonry walls: 1/4" expansion bolts [Section 1.4, Figure <b>G</b>] Tightening torque: 8.8 Nm (78 lb-in)</li><li>- Drywalls supported by wooden posts: Wood screws [Section 1.4, Figure <b>E</b>] with a screw length of at least 50 mm (2") Tightening torque: 3 Nm (26 lb-in)</li></ul>
	<p>3. Align the screw holes on mounting bracket [Section 1.4, Figure <b>B</b>] and the product.</p> <p>4. Install and fasten the product on the mounting bracket [Section 1.4, Figure <b>B</b>] using the supplied Torx T30 [Section 1.4, Figure <b>F</b>]. Tightening torque: 1.5 Nm (13 lb-in)</p>

## 4.5 Removing the covers

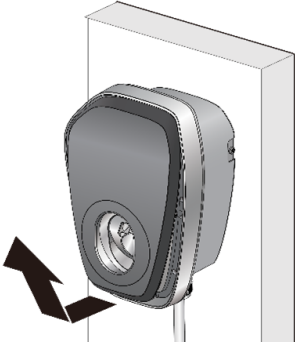
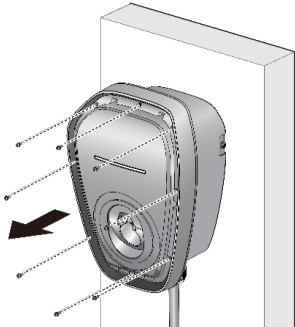
	<p>5. Remove the design cover. [Section 1.4, Figure D]</p>
	<p>6. Use a T20 screw driver to remove the screws securing the middle cover. Torque: 1.4 Nm (12 lb·in)</p> <p>7. Remove the middle cover.</p> <p><b>The middle cover has to be removed carefully and held parallel during the process. Do not tilt while removing. Do not remove any other screws apart from the above-mentioned screws.</b></p>

## 4.6 Securing the anti-theft screw

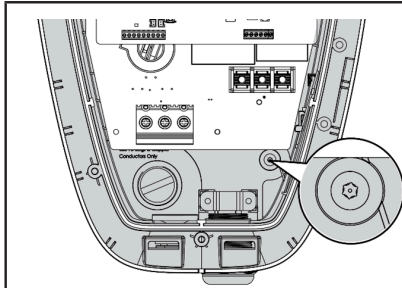

8. The hole for the anti-theft screw [Section 1.4, Figure **H**] is covered by a void label.

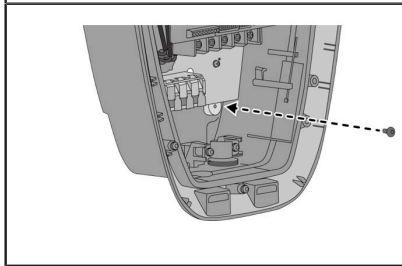

9. Tighten anti-theft screw [Section 1.4, Figure **H**] through the void label.  
Tightening torque: 1.2 Nm (10 lb·in)

## 5 Connect terminal

Use an appropriate copper wire with listed pressure terminal connectors, such as a ring and fork type, on the end of the conductor before attaching to the terminal blocks. Keep enough wire length to facilitate installation.

Suggested conductor and conduit specification: Choose an appropriate conduit in accordance with all applicable local, state and national electrical codes and standards. Make sure the circuit breaker is turned off before installation.

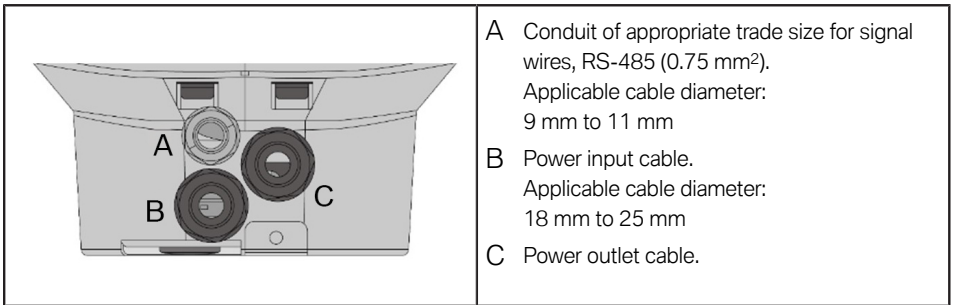

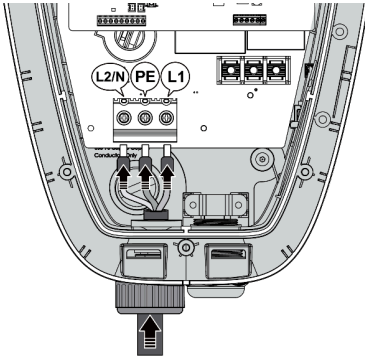

Ensure that hazardous voltages are isolated safely. ⚠

### Detailed diagram for item 2:

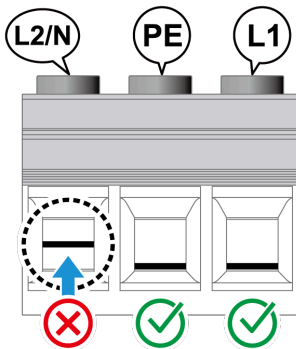

### Cable Connection Procedure

#### 1. Stripping Length Preparation:

The stripped length of the input cable should be **18 ~ 19 mm (0.71 ~ 0.75 in)**. This indication is displayed simultaneously near the terminal block.

#### 2. Loosening the Terminal Screw:

Before inserting the wire, turn the screw on the terminal **counterclockwise** until you hear a continuous **clicking sound**. Take care of the detailed diagram for item 2 on the left-hand page.

#### 3. Inserting the Wire:

Connect each wire to its corresponding terminal (L2/N, PE, L1) in the terminal input block.

#### 4. Tightening the Terminal:

Using a **PZ2 Phillips screwdriver** or a **1 x 5.5 mm flathead screwdriver**, securely tighten **clockwise** each terminal **individually**. Perform a manual tug test on the wire to confirm that the connection is solid and the conductor does not slip out.

#### 5. Torque Requirements (Critical):

The recommended tightening torque is 3.8 Nm (34 lb-in). The **acceptable torque range** is **3.8 Nm ~ 4.4 Nm**.

#### 6. Best Practice:

For best results and to ensure connection reliability, please use a **calibrated torque wrench** or a **preset torque driver** for the tightening procedure.

# 6 Configuration via Wallbox Installation App

## 6.1 Wallbox Installation App

You must use the Installation Wizard in the Wallbox Installation App to configure the BMW Wallbox Plus.

If the Installation Wizard has not been completed successfully, charging is not possible.

The installer or BMW service partner must use the Service and Wallbox Installation App to configure the device, download the charging history and diagnosis, update the firmware and rectify errors.

This manual lists all systems and functions that are currently offered. It therefore also describes systems and functions that may not be available at your location due to specific market conditions or the specific installation and configuration.

Some functions may only be accessible via the expert mode in the Wallbox Installation App.

The expert mode is provided for specialists such as qualified electricians to use the Installation Wizard and to change settings related to the mains or back end. The usage of this function is not recommended for general users. The password for accessing expert mode is: **1916**

### Features

- Installation Wizard
- Diagnostics data
- Wallbox status
- Live data
- Wallbox configuration
- Authorisation settings (RFID)
- RFID card management
- Data connection configuration
- Electrical configuration
- Password management of the Wallbox Installation App
- LED indicator brightness
- Installation guide
- Firmware upgrade
- Reset wallbox

**The app is available in all relevant app stores.**



Wallbox Installation App for iOS



Wallbox Installation App for Android

## 7 Commissioning



Ensure that the rubber seal is mounted correctly before commissioning. ◀

	<ol style="list-style-type: none"><li>1. Check the perimeter rubber ring before installing the middle cover.</li><li>2. If the rubber ring is detached or is not fitted properly (as shown), use your fingers to press it back into the groove.</li><li>3. Ensure the rubber ring is flush with the surface and securely seated (✓) before proceeding.</li></ol>
	<ol style="list-style-type: none"><li>4. If the rubber ring is largely or completely detached, locate the four T-shaped anchor points indicated by the arrows.</li><li>5. First, insert these four anchor points into their corresponding slots in the groove to establish the correct orientation and position.</li><li>6. Then, working in segments between the anchors, press the remaining lengths of the rubber ring evenly into the groove until fully seated.</li></ol>

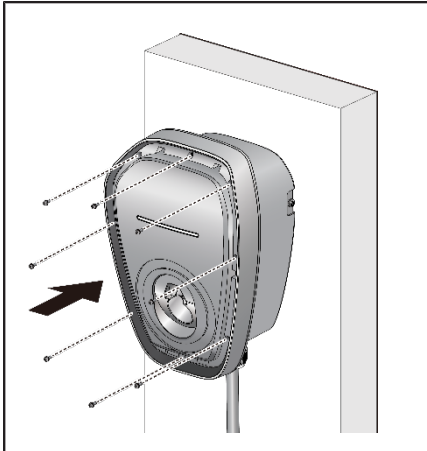

Install the middle cover.  
Torque: 1.0 Nm (8.7 lb-in)

**The center cover must be mounted parallel and carefully.**

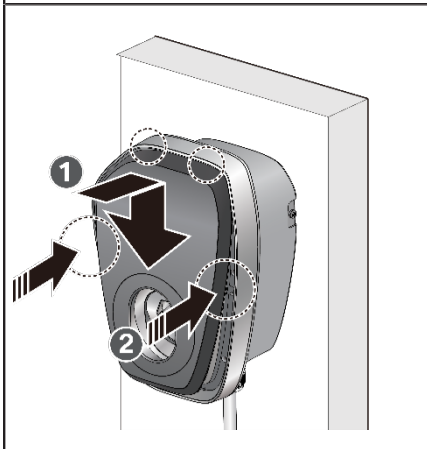

Install and lock the design cover **D**.



An audible click sound denotes a closed faceplate. ◀

## 8 Operation

The BMW Wallbox Plus is supplied with access control via app deactivated as standard. If you would like to use access control, please adjust the configuration accordingly in the Wallbox Installation App. For further information, see Section 6.

For access control via RFID cards, charging cards must be registered using the setup card. The BMW Wallbox Plus is supplied with two RFID cards.

For access control via automatic vehicle detection (MAC authentication), vehicles must be registered using the setup card. You can use this authentication option with the following vehicles that support communication in accordance with ISO 15118.

For use with all BMW fully electric and hybrid vehicles from vehicle software 03/26, except BMW i4 (G26) and BMW iX3 (G08).

### 8.1 Starting the charging process with access control deactivated

1. Connect the vehicle connector to the vehicle inlet.
2. The vehicle will start the charging session automatically.

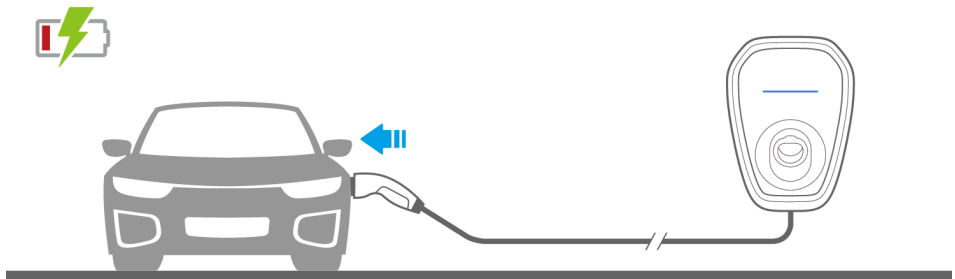

## 8.2 Terminating the charging process with access control deactivated

1. Stop the charging session at the vehicle.
2. Disconnect the vehicle connector from the vehicle inlet.
3. Place the vehicle connector back into the vehicle connector inlet of the BMW Wallbox Plus.

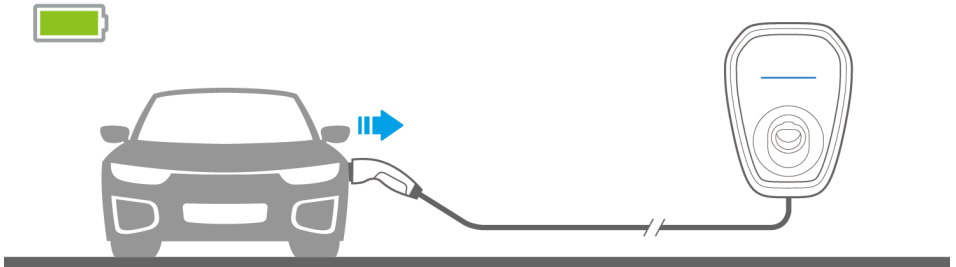

## 8.3 Starting the charging process with access control via RFID card activated

1. Connect the vehicle connector to the vehicle inlet.
2. Hold the RFID card in front of the RFID reader to authorise and initiate the start of the charging session.

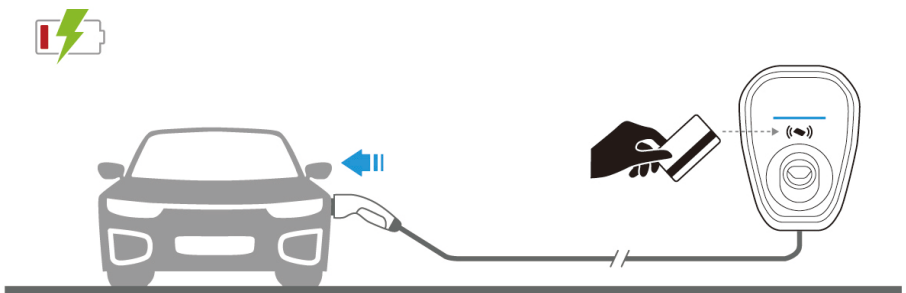

## 8.4 Terminating the charging process with access control via RFID card activated

1. Stop the charging process at the vehicle, via the My BMW App or the RFID card.
2. Disconnect the vehicle connector from the vehicle inlet.
3. Insert the vehicle connector back into the vehicle connector inlet on the BMW Wallbox Plus.

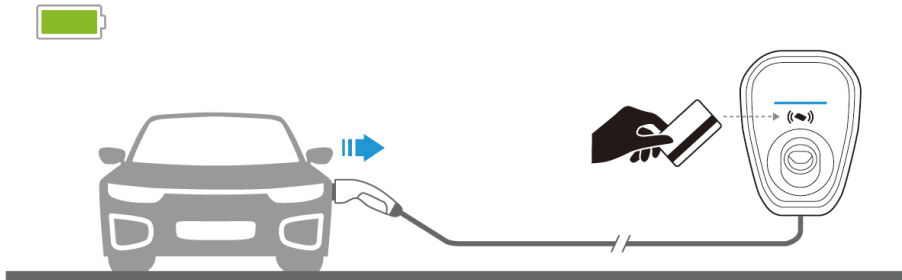

## 8.5 RFID card registration and registration for access control via automatic vehicle detection (MAC authentication)

The BMW Wallbox Plus uses two different kinds of RFID Cards:

- A Setup Card to notify the Wallbox to turn on/off registration mode
- Charging Cards to control the start/end of charging





For more information on how to charge using the charging card, please refer to Section 8.

In addition, you can also register vehicles for access control via automatic vehicle detection (MAC authentication) at the BMW Wallbox Plus. If you use this automatic authentication method for the vehicle, access control via RFID card is no longer necessary.

Please find the instruction for manual registration of new charge cards or vehicles for access control under 8.5.1 and 8.5.2.

### 8.5.1 Registration of new Charging Cards

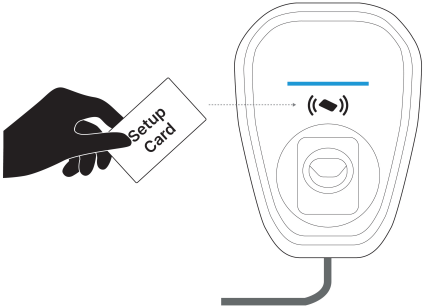
**Notice: Additional charging cards must meet the “MIFARE” standard.**

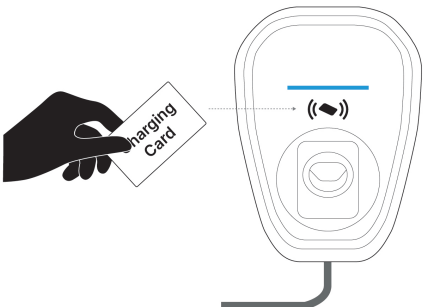
	<p>1. The BMW Wallbox Plus needs to be powered on, DO NOT connect the charging cable with the vehicle. The LED bar should display a steady blue light.</p>
<p> 1 Short Beep</p> 	<p>2. Hold the setup card in front of the RFID reader to start the registration mode for new charging cards. The start of the process is confirmed by a short beep.</p>
<p> 2 Short Beep</p> 	<p>3. Hold the new card in front of the RFID reader to register it at the BMW Wallbox Plus. Registration is confirmed by two short beeps. Repeat this process with any other RFID cards that you want to add.</p>

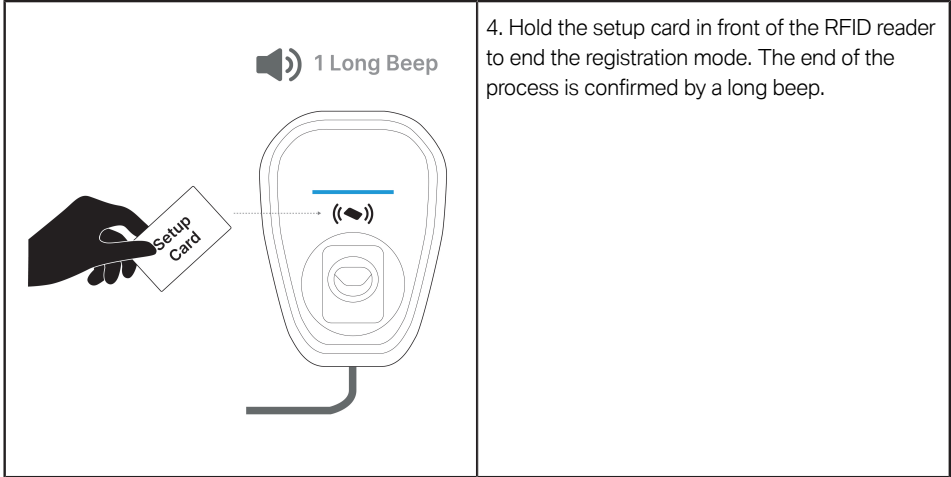



The BMW Wallbox Plus is supplied with a preregistered setup card which can be used to register new charging cards. A new setup card can be registered via the Wallbox Installation App (see Section 6).

### 8.5.2 Registering new vehicles for access control via automatic vehicle detection (MAC authentication)

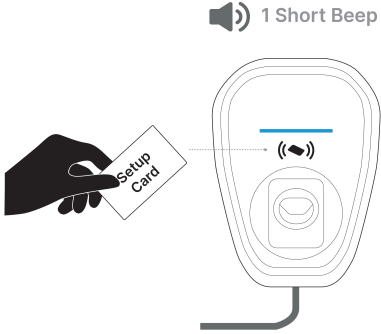
For vehicle selection and criteria, see Section 8 "Operation".

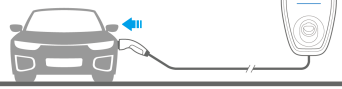
	<p>1. The BMW Wallbox Plus must be switched on. Do NOT connect the charging cable to the vehicle. The LED bar should display a steady blue light.</p>
	<p>2. Hold the setup card in front of the RFID reader to start the registration mode for new vehicles. The process is confirmed by a short beep.</p>

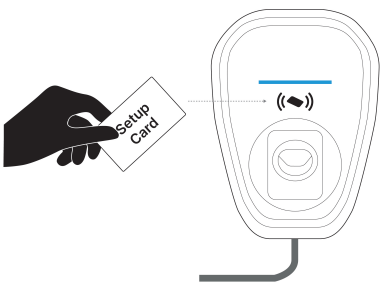
<p> 2 Short Beep</p> 	<p>3. Connect the vehicle connector to the vehicle inlet to register the vehicle at the BMW Wallbox Plus. Registration is confirmed by two short acoustic signals. Repeat this process with any other vehicles that you want to add.</p>
<p> 1 Long Beep</p> 	<p>4. Hold the setup card in front of the RFID reader to end the registration mode. The process is confirmed by a long beep.</p>

## 9 Status LED information

LED indicator	Status
Blue, flashing from left to right	BMW Wallbox Plus initialisation in progress. BMW Wallbox Plus is suspended temporarily.
Blue	Vehicle is not connected, standby.
Blue, breathing	Vehicle is charging.
Red	Error
Blue (S1/S2/S3), Red (S4)	Communication module is damaged or defective on standby. (The control pilot is in the state A1, A2, B1, B2 or C1)
Blue (S1/S2/S3) breathing, Red (S4)	Communication module is damaged or defective on charging. (The control pilot is in the state C2)
Blue (S1/S2/S3) flashing from left to right, Red (S4)	Communication module is damaged or defective during the firmware update.



# 10 Maintenance

## Annual requirements

1. Conduct a visual inspection of the charging cable and ensure that the cable does not show any visual damage or deformation.
2. Conduct a visual inspection of the charging coupler and ensure that the coupler does not show any visual damage, arcing or rust.



To avoid danger of electric shock or injury, turn off power at the panel board or load centre before working on the equipment or removing any component.

Do not remove circuit protective devices or any other component until the power is turned off.

Disconnect electrical power to the EV charging solution before any maintenance work to ensure that it is disconnected from the supply of AC mains.

Failure to do so may cause physical injury or damage to the electrical system and charging unit.



- Touching the circuit before the main breaker and auxiliary breaker are switched off may be hazardous. The switching device and other apparatuses can only be inspected visually.
- Maintenance of the EV charging solution shall be conducted only by a qualified technician.
- After opening the front panel, turn off the main breaker and auxiliary breaker before any maintenance work. ◀

## Cleaning

Regular cleaning of the PowerUp Charger is recommended. During the charger stand-by state, use a soft, lightly dampened cloth with clear water to remove any dirt, ensure that no water enters the charging coupler.

## 10.1 Troubleshooting

<b>Situation</b>	<b>Action</b>
LED indicator is not powered.	<ol style="list-style-type: none"><li>1. No supply voltage – check the residual current breaker and power circuit breaker and switch on if necessary.</li><li>2. Error on the BMW Wallbox Plus – contact your local dealership.</li></ol>
Charging session is not started.	<ol style="list-style-type: none"><li>1. The vehicle connector has not been inserted correctly – remove the vehicle connector and reconnect it.</li><li>2. The vehicle has been programmed to start the charging session at a later point of time.</li><li>3. The vehicle does not require any energy – check the vehicle status.</li><li>4. App connection is not working correctly – follow the instructions in the manual.</li></ol>
Vehicle connector cannot be disconnected.	The charging session has not been ended by the vehicle.
LED indicator illuminated in red.	<ol style="list-style-type: none"><li>1. Check the possible causes of the error.</li><li>2. Switch off the supply voltage to the BMW Wallbox Plus using the appropriate mains isolation device.</li><li>3. Disconnect the vehicle connector and switch on the supply voltage again.</li><li>4. If the situation persists, contact your local dealership.</li></ol>

## 11 Moving and storage

- Improper moving or storage of this device may result in a risk of fire or electric shock.
- Do not lift or carry the unit by the cord.
- Do not allow the connector cable to drag or touch the ground when moving the unit.
- This unit should be stored in a dry location between -40°C and 80°C.

When carrying and moving this product, do not pull on the cable or cord **strongly**.

## 12 Technical data

### Electrical data

Vehicle connector	NACS
Input/output rating	120 V, 20 A max., 60 Hz, single phase 208 V / 240 V, 64 A max., 60 Hz, split phase
Input wiring	L2/N, PE, L1
Grounding system	TN/ IT/ TT
Rated current (adjustable rated current via Wallbox Installation App)	6 A – 64 A
Cable length	25 ft.
Cable feed	Surface-mounted
Maximum connection cross-section	3 AWG*
Internal residual current detection	AC: 15-20 mA
Protection against electric shock	Class I
Ingress protection (indoor and outdoor areas)	NEMA 3S
Dimensions (W x H x D)	270 x 370 x 185 mm
Weight	7.3 kg
Electrical protection	Overcurrent, short circuit, overvoltage, undervoltage, ground fault, overtemperature protection and surge protection, relay welding protection

\*Choose an appropriate conductor in accordance with all applicable local, state and national electrical codes and standards. Make sure the circuit breaker is turned off before installation.

## Interfaces

Indicator	LED bar indicator
Communication	Bluetooth, RFID, Ethernet, ISO15118, OCPP, WiFi

## Ambient conditions

Operating temperature	-40°C to +50°C
Temperature properties	This is not a safety device, it is just an operating function. The specified operating temperature range must not be exceeded. The device supplies the charging current continuously at the specified operating temperature ranges. When overtemperature protection occurs, the EVSE will stop charging. The charging will continue automatically after the EVSE has cooled down.
Storage temperature	-40°C to +80°C
Humidity	95% relative humidity, non-condensing
Altitude	3,000 m
Cooling	Natural cooling
Impact protection	IK09
Overvoltage category	OVC III
Cold load pick-up	Randomised delay between 1 and 120 seconds before charging restart after power outage

## For Mexico

“Para su uso en México, la operación de este equipo está sujeta a las siguientes dos condiciones: (1) es posible que este equipo o dispositivo no cause interferencia perjudicial y (2) este equipo o dispositivo debe aceptar cualquier interferencia, incluyendo la que pueda causar su operación no deseada.

Localización del IMEI: El IMEI se localiza en una etiqueta adherida al reverso de su equipo y/o en la etiqueta adherida al empaque”



The available charging capacity depends on the vehicle, the infrastructure and general settings. ◀



Extension cables must not be used. ◀

## 13 Disposal



After correctly decommissioning the device, please have it disposed of by the service department in compliance with current waste disposal regulations.

The electrical and electronic devices including accessories must be disposed of separately from general household waste. There are instructions on the product, in the instructions for use or on the packaging.

The materials can be recycled as shown by their labelling. You can make a significant contribution to protecting our environment by reusing, recycling the material or other forms of recycling of end-of-life devices.





**RACCOLTA CARTA**  
Verifica le disposizioni  
del tuo Comune.